

## PHOTOGRAPHY FOR INSTRUMENT MAKERS

Terry Borman and Scott Rawley  
1221 Rodgers Drive, Fayetteville, AR 72701  
[terryborman@bormanviolins.com](mailto:terryborman@bormanviolins.com)

### *Abstract*

*This article is intended to inform the typical working luthier about some of the more important aspects of photographing instruments of the violin family. We also describe a portable system that can enable those who need to photograph instruments away from the shop setting to arrive at satisfactory results.*

Photographing musical instruments of the violin family is notoriously difficult; even professional photographers have difficulty obtaining high-quality images. Such photography is of great interest to makers, players, dealers, curators, and enthusiasts. Instrument makers, particularly, are increasingly reliant on the photographic image as a tool in studying and recreating historic instruments. For example, making a bench copy of a fine instrument was once done with the original instrument on the maker's workbench, easily available for detailed examination throughout the process. However, as instruments increase in value, musicians are less likely to leave valuable instruments in the maker's shop for any significant period of time. Photography provides a partial solution to this problem of limited access to fine instruments. In addition, the knowledge base of all instrument makers rises with greater access to higher resolution photographs.

A number of authors have published articles on violin photography [1-5], and the interested reader will find details in the Reference section. Probably the best all-around information about photographic principles is the trilogy of books by Ansel Adams: *The Camera* [6], *The Negative* [7], and *The Print* [8]. After assimilating the information in these books, there is a variety of books leading in every conceivable direction.

This article will describe equipment and methods that we have found useful for photographing fine instruments and as an aid in studying instruments in general. Included are photographic equipment (cameras, lenses, lighting, light meters, film, tripods), studio design, and methods.

The authors acknowledge that significant personal preferences influence what is written in this article and that even these change over time. For example, we much prefer black and white (B&W) photography for its intrinsically higher resolution and to avoid the complications of color correction. Further, the archival stability of properly processed B&W prints is a known quantity at this time, while the permanence of color prints is still waiting for the ultimate test of time.

## *Equipment*

### *Cameras: Digital or Film*

Anyone venturing into the realm of photography has an array of choices regarding the camera. The most commonly chosen option these days is digital. This format has many advantages, but some drawbacks compared to traditional film cameras. The chief advantages of digitally recorded images are that the cameras themselves are rather inexpensive (many are less than \$1000) and one can immediately view and easily manipulate the pictures with imaging software. All of this is very seductive. However, it should be emphasized that in photography the principal expense is for the lens.

There is no known process to make a high-quality, inexpensive lens, and there is no way to get a high-quality photograph with a low-quality lens. Many professional photographers are "going digital," but this does not mean they are using \$300 digital cameras. They are using very sharp lenses mounted to high-quality camera bodies and are simply replacing the film holder with a digital back. To achieve the quality referred to in this article, one should expect to pay upwards of \$10,000 for a digital back with similar resolution to that possible with film.

For many people, a better alternative to an inexpensive digital camera is a traditional film camera with high-quality optics and interchangeable lenses. With the exodus to digital, one can buy used 35mm or larger film cameras at fire sale prices, generally for a few hundred dollars. One can have a significantly sharper photograph than with an inexpensive digital camera, but still have many of the advantages of digital simply by having the film images scanned at the photo lab, usually at the same time as the film is being developed. If cost is not the primary issue, then one can acquire a high-quality digital camera with interchangeable lenses<sup>1</sup> and achieve very admirable results. For that

matter, one can buy a digital back for a medium- or large-format camera and have some of the highest quality hardware available. Of course, final quality will depend, as in most endeavors, on the photographer's expertise.

If one uses a digital camera, the clarity of the prints will be limited by the printer resolution and the print size. There is no point in having a 6-megapixel camera if the prints will be produced on a home printer capable of rendering 300 dpi and only enlarging to 5 in. x 7 in. However, professional labs have printers with much higher resolution than generally found in small business or personal use, so one needs to do a little math and be realistic with one's expectations.

### *Camera Formats*

Let's take a moment to review the three analog formats available to photographers. The smallest, and most familiar, is 35 mm, which is the measure of the diagonal film size. From there, one moves to what is called "medium format," of which there are three general types. The most common size is 6 cm x 6 cm, epitomized by the Hasselblad line of cameras, but also available in a 6 cm x 7 cm format such as the Mamiya line. An advantage of the Mamiya line is that the rectangular negative is closer to the outline of a violin family instrument, i.e., long and thin. Several manufacturers also make 6 cm x 4.5 cm cameras. From medium format one moves up to the "large format," the most common of which is the 4 in. x 5 in. camera.\*

### *Lenses*

One should acquire the highest quality lens one can afford, and this is a situation where expenditure is directly proportional to quality. For photographing stringed instruments, a lens with a relatively long focal length (FL) is advantageous because it produces less distortion. With a long-FL lens you won't have to look as much up or down to encompass the entire instrument. Therefore, for the 35mm format a "normal" lens has a focal length of 55 mm, although for instruments one would be better served by a lens FL of 90 mm or longer. For medium-format cameras, normal is 90 mm, so 125 mm or longer would provide less distortion. For large-format cameras one can use the general rule that the lens FL should be ~10 to 25% greater than the diagonal of the film.

---

\*Measuring systems are mixed; smaller formats are in metric dimensions, medium formats are in metric or inches (6 cm x 7 cm is also referred to as 2.25 in. x 2.75 in.), and the dimensions of larger formats are in inches (4 x 5, 5 x 7, 8 x 10, etc.).

### *Lighting Equipment<sup>2</sup>*

We have found that color-corrected 500W photoflood light bulbs work well. Please remember that the bulbs must be color corrected for the type of film used: tungsten or daylight. In most cases it is worth the minimal additional expense to have a set of each on hand. They are inexpensive and, once inserted into an “off the shelf” architectural lamp, provide great flexibility in lighting directionality. (“Off the shelf” does not refer to the extremely inexpensive architectural lamps that are usually limited to 60W or less, but to the higher quality lamps with porcelain sockets rated for use with 100W bulbs. In our shop, using them with 500W bulbs for short periods of time has not been problematic.) Generally, four of these lights will provide enough quantity and quality of light. Another option is to go the route of the professional photographers’ lighting systems, e.g., using Lowell Tota lights or similar, but this may prove to be cost prohibitive for the luthier that only occasionally photographs instruments. (See Refs. [1-6] for more on this subject.)

It is useful to install all of the lights on dimmer or on/off switches located close to the tripod since it is then very easy to use less light to compose the picture and even turn off the lights between shots to avoid heat build-up. The dimmers can also be used in B&W photography to adjust exposure for each quadrant of the picture. This will save a lot of time burning and dodging in the darkroom. Dimmers must not be used for color photography because dimming changes the effective color temperature of the light, which will result in odd colors in the finished product.

### *Light Meters*

There are two general types of light meters: those that measure the incident light at the object and those that measure the reflected light arriving at the camera. Cameras with a built-in meter, including most with a 35mm format, use the reflected light system. Another type of reflected light meter is a spot meter that measures a small area, usually within a 1° or 2° cone angle. This can be very useful as it is easy to be sure that each quadrant of an instrument back or belly is receiving the same general amount of light. Color film is somewhat less sensitive to these variations, but with B&W film a quarter-stop difference may require quite a bit of burning or dodging work in the darkroom to arrive at a suitable print.

Incident light meters work very well for musical instruments, also. Probably the most effective meter for most people is the meter that they already have, remembering that one must take the time to learn how to use it to best advantage. One bit of advice bears repeating: *for negatives slight overexposure is much*

*better than slight underexposure and for positives the opposite is better, i.e., slight underexposure.*

### *Film*

Films are another example of inverse proportionality to our needs, i.e., the slower the film speed, the higher the resolution. Slower film complicates lighting, tripod choices, supports, etc. Therefore, the slowest film one can use will yield the highest resolution. We generally prefer to use B&W film, which has traditionally been more stable than color film for both the film and the print processed for archival use. Kodak's TMAX 100 works well, although just about any relatively slow film will give good quality, depending on the photographer's preferences and experience. (Our current preference is Ilford's Professional Delta 100 film.) For color work we have used negative film with reasonable success, although we have recently begun experimenting with color transparencies (Kodak Ektachrome 64T) in an attempt to arrive at truer color rendition. Color prints have traditionally been less stable than equally well-processed and stored B&W, but this is changing. However, people usually prefer color. The principal problem with color is that images of instruments rarely have correct colors, even when the best labs are aided by input from instrument makers. Unfortunately, over time it is easy to forget this disparity from the original, which can lead the maker down a slippery slope of strange varnish colors.<sup>3</sup> After many attempts over the years to arrive at more accurate colors, no particular approach seems to be superior. Our recommendation is to include a calibrated color and B&W strip in each picture as well as a penny (or similar object) taped to the background that is then given to the lab as a further reference point. Probably the best route in selecting film is to find a high-quality lab with which you are comfortable and ask the person doing the processing and printing what will give the best results for your goals; photo labs are generally very up to date with products. In the long run it is preferable to establish a relationship with a high quality lab that you are comfortable working with as opposed to an inexpensive lab unwilling to work with your demands.

### *Tripod*

The choice of a tripod should be carefully considered. One must use, at all times, the sturdiest tripod for the particular format. A tripod that is sufficiently sturdy for three-minute exposures with a 35mm camera may not suffice for a one-sec. exposure with a large-format camera. The best tripods are heavy. Consideration should be given to the usable range of the tripod, as many tripods will extend much farther than the range at which they are actually effective.

### *Photographic Equipment Used by the Authors*

We have used all of the mentioned formats and have currently settled with a medium-format camera, a Mamiya Model RB67, which has a rotating back to allow one to simply rotate the back of the camera rather than the whole camera when switching from a vertical to horizontal format. The Mamiya uses a 6 cm x 7 cm negative, which is the minimum negative size if one plans to enlarge negatives to the full size of the instrument back, belly, or side. (Some photographers suggest that this can be achieved using 35mm format, given the high quality of today's films). We use a Mamiya 127mm FL lens, which is slightly shorter than ideal. We also use an 8 in. x 10 in. sheet film camera in our studio and get about 9.5 in. of a 14-in. violin back on film (the button is "lost area"). Excellent documentation of an instrument is obtained using a contact sheet, as well as a 5-in. x 7-in. reducing back on this camera, to get 1:1 photographs of scrolls. The much more common 4 in. x 5 in. back can be used, but the scroll is somewhat "cramped" in the photograph as the scroll is generally ~11-cm long, or almost 4.5 inches. For our medium-format camera we use an older Bogen *Model 3001* tripod; for the large-format camera we use a Majestic tripod. The quality of the Majestic tripod is excellent, although it is not recommend it for smaller format fieldwork because of its weight.

## *Studio Design*

### *In-House Studio*

Our current shop arrangement includes an extremely sturdy support plus flexible lighting—the two main concerns of the photographer of valuable stringed instruments. Each quality must, however, be obtained independently. Sturdiness is achieved by having the instrument holder, as described in the following section, embedded in concrete, or a similarly sturdy design to eliminate movement of the base support and avoid any possible damage to the instrument. Flexibility with lighting is obtained using relatively inexpensive architectural lamps, as previously mentioned, mounted to the wall behind the support system. It is important that these lights be adjustable to avoid reflections and glare from the instruments due to the arching. This design makes it possible to move the lights without affecting the instrument, as the lights are separate from the instrument support fixture.

Depth of field is worth mentioning since due to the shape of the violin, most pictures need a significant amount of "area in focus." This is obtained by using smaller apertures with the natural downside of aperture size being, once again, inversely proportional to shutter speed. Commonly, exposures of one second

or longer, and at times up to several minutes, are necessary. A significant advantage is obtained by leading all of the light cords to individual dimmer switches so that each quadrant of the image (upper left bout, upper right bout, etc.) can be controlled independently. These are then positioned next to the photographer so that he or she can modulate lighting intensity from the viewfinder of the camera (for color work use only the on/off aspect of the switches).

### *Portable Studio*

Most luthiers must travel to view and study fine instruments, although this does not mean that one must necessarily forgo expectations for high-quality photography. The following design of a portable violin photo studio was developed after a commission from a violinist in New York for a copy to be made of a violin by Giuseppe Guarneri *del Gesù*. The sturdy mounting structure and flexible lighting configuration used in our studio could not be easily transported to New York, and so a new portable system was necessary. After several aborted trials the following system was developed, which worked well. The instrument was safe during the process, and the photographic resolution was sufficiently clear to obtain full-size prints of the body and scroll and almost 3:1-scale prints of details of the instrument. All photos were very sharp and detailed. An advantage of this design is that it can be stored and reassembled as needed to save space. Also, it can serve double purpose as one's primary studio arrangement.

The details are not easily described, so we provide drawings of the instrument support structure in Figs. 1a-d. The base is made of copper tubing (0.75-inch dia.), which is inexpensive, easily obtained at any hardware store or plumbing supply house, and allows great flexibility in design.<sup>4</sup> It also allows for flexibility to account for forgotten details or new features later. The tools required in its construction include a tubing cutter, copper tubing, various copper joints, solder, flux, and a small butane torch. The total cost for tools and parts is ~\$60 to \$80.

Originally, the structure was planned to be narrower, but the architectural lamps needed the given dimensions as a minimum to allow for their movement. When packed, the two structures lay upon one another with a combined height of 5 inches, although a slightly larger box, ~8-in. high, was used to allow room for the hoods of the lamps, which were placed in the same box suitable for checked baggage for air transport. The legs were cut with a tubing cutter to be a minimum height that would center the instrument level with the lens using a tripod in its sturdiest range. With our camera and tripod, these legs are 13.5 in. long, and copper caps are placed on the ends to protect the floor from scratches. The design is such that removing the legs and placing



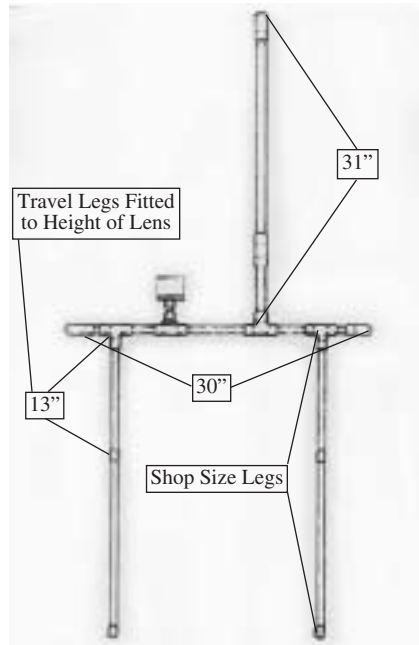

Figure 1a

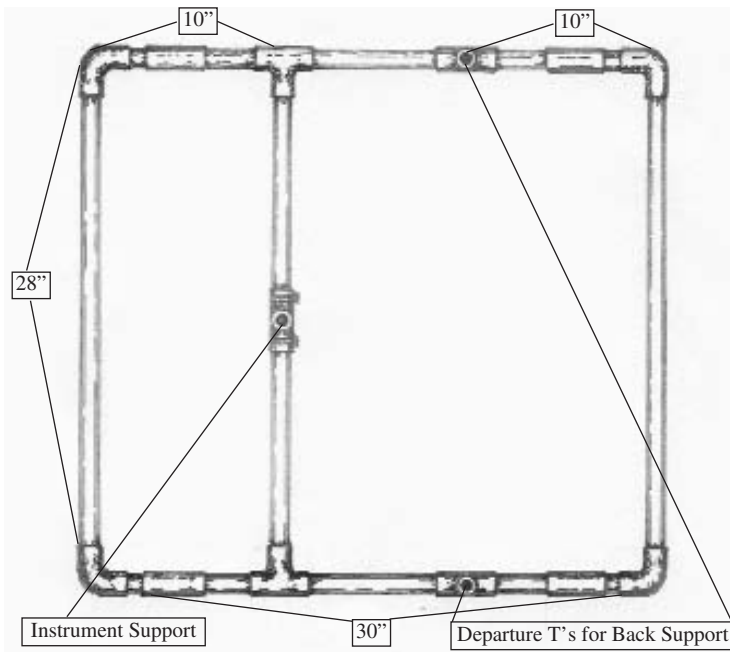

Figure 1b



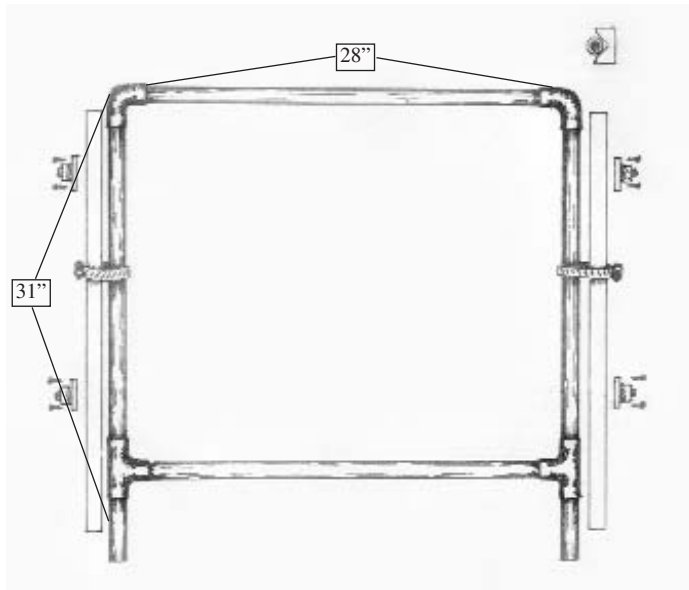

Figure 1c

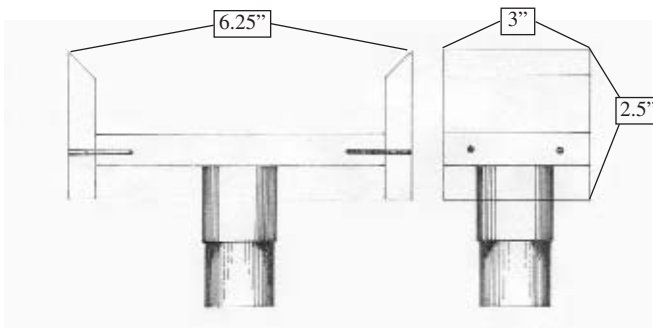

Figure 1d

Figure 1. Instrument photography support structure: a) side-view, b) top view, c) front view, and d) instrument mount, two views.

the base structure on the ground brought the scroll to a good height, and it is only necessary to raise the tripod slightly for scroll shots. The other alternative, raising the tripod significantly, was ruled out because vibration and movement are greatly exaggerated.

Onto the background wall sides, a more suitable material was needed for mounting the lights than the round tube, so 1-in. x 2-in. poplar wood cut to the length of the vertical sides was chosen. After cutting out a V on the backside to give a larger gluing surface, the wood was epoxied to the copper. The wood/copper joint at each end was reinforced with hose clamps as a safety measure (see Fig. 1c). The lamp holders were screwed onto these wood pieces. As a background, white photographic roll paper was used, cut to width and held in place at the top with two pressure clamps, one at each side. The paper went down the vertical, curved gently at the 90-degree angle of the support base, then onto the instrument support where a hole was cut for the vertical T joint, and to the front edge where it was held in place by two more pressure clamps.

The actual support for the violin was a modified version of the standard shop support (Fig. 1d), i.e., a Plexiglas base with two vertical sides to support the instrument. We have always chosen to drill through the sides into the base and insert wood dowels as extra support in the corners. Another option is to glue Plexiglas triangles in the corners as reinforcement, although they can be somewhat more noticeable in the final print if the verticals are not tall enough. To adapt this to the 0.75-in. T in the center of the base, another piece of Plexiglas was cut to the same dimensions as the existing base, and a hole was drilled in its center the size of a 0.75-in. in-line connector. The second base was glued to the first, and a 0.75-in. in-line connector was epoxied into the hole. This allowed for modification of the height of the support as needed by simply changing the length of the copper tube between the instrument support and the base T.

Since many old instruments have become skewed by time, weather, repairs, etc., the T at the center of the base structure designed to hold the violin support was not soldered as the other joints. Instead, the T was held in place with a hose clamp on each side of the in-line section. With this feature "vertical" could be modified to assure that the instrument is well balanced on the support and also to keep the plane of the instrument as close as possible to the film plane to minimize distortion. (This is not possible for full instrument shots since the camera must be tilted up to include the scroll, unless using a view camera.)

To set up this structure takes about five minutes since all one needs do is insert the background frame into the base support, insert the legs, clamp the paper in place, insert the instrument

holder, and insert the lamps into their supports. For the electrical supply, a computer multi-plug outlet that can handle 2 kW is used since the bulbs use 500W per lamp (or the individual dimmers as previously mentioned).

With this, the lights could be turned off easily between shots so it was not necessary to touch the structure, which could shake the instrument. This arrangement, as outlined, is not particularly small or extremely light (aluminum would be noticeably lighter), but it is affordable and sturdy. It does an excellent job at replicating the studio environment and is something that anyone can easily build.

### *Methods*

There are many simple techniques and “tricks” that may take a long time to learn when photographing instruments. We hope that this part of the article will help the photographer-in-training avoid the most common pitfalls of instrument photography. The following information is applicable to digital, 35mm, medium-, and large-format photography.

Once a studio setup as described is assembled, the violin is set in place, taking care that it is in good contact with the support. Always check the following:

- That the instrument is vertical and not tilting too much to the left or right relative to the bass and treble sides. “Not tilting too much” refers to rib deformities, chinrest placement if left on the instrument,<sup>5</sup> and other factors that affect the ideally sturdy placement, which supersedes the exact vertical placement that can be modified at the camera to appear vertical.
- That the instrument is vertical in the side view, i.e., top to back. This can be modified as needed by removing the instrument, loosening the pipe clamps holding the copper support T in place, altering as needed, re-tightening and putting the instrument back in place. Although this process may take a bit more time, it is well worth it for the instrument’s security and your peace of mind.

When taking full instrument photographs, there are basically two points of interest: the body and the scroll. With any camera other than a large-format model it is impossible to render both with a minimum of distortion, because the lens must either point a bit upward to include the scroll or downward to completely encompass the body. Of course, one could place the camera far enough away from the instrument for this to be negligible, but the instrument would be very small in the photograph and one

would need to enlarge much more than is otherwise necessary. This would also greatly increase the graininess of the final print.<sup>6</sup> Since it is most important for photographs of the body of the instrument to have the least amount of distortion, the camera should be set up with the lens is approximately level with the bridge. One could measure this height and adjust the camera accordingly, but it is much easier to look through the viewfinder and adjust the height of the tripod to see an equal amount of the four back corners, e.g., of the front shot. The same technique is used to arrive at the correct lateral placement of the camera, although for this one must move the tripod either to the left or right to equalize the rear corner view (once again for the front shot). This is usually a good starting point to use for photographs, modifying as needed to mediate any peculiarities of the instrument. Tilting the camera slightly upward will be necessary to include the scroll. This same general technique is used for all of the photos and it works well as an alignment plan.

The basic order of photographs is as follows:

1. Full instrument, front
2. Belly, full frame
3. C-bouts, front (close-up of the bridge area with upper and lower corners)
4. Full instrument, back
5. Back, full frame
6. C-bouts, back (close-up of the central back with upper and lower corners)
7. Full side view
8. Side view of body, full frame
9. Scroll, bass side, full frame
10. Scroll, front, full frame
11. Scroll, treble side, full frame
12. Scroll, back, full frame

These are the basic views for a violin. If there is time and the instrument is significant, additional photographs can be taken using the extension tubes for greater detail. (For the Guarneri *del Gesù* violin, the impetus for our portable studio design, over 60 photographs were taken.)

A necessary accessory for any type of camera is a shutter release, and for medium-format cameras, a double shutter release is needed. With a double release, partial pressure raises the mirror and further pressure trips the shutter, allowing any vibration from the mirror movement to stop. This is especially important for close-up work or anything nearing a 1:1 ratio or greater.

### *Aperture Settings*

Most photographic lenses are designed to give their maximum sharpness and acutance (what the eye perceives as sharpness) at an aperture approximately one-third to one-half shut down from maximum (the smallest f-stop number). However, violin photography requires a surprisingly large depth of field (the area in front of the lens that is in focus). If one focuses on the belly of a violin using a large aperture, the bridge and strings, as well as the edges, will probably be out of focus. To increase the depth of the subject field that is in focus, one needs to use smaller apertures. The same photograph with an aperture of f16 or higher would have the strings, bridge, belly, and likely the rear corners in sharp focus. However, with a very small aperture (long depth of field), the shutter speed must be slowed enough to allow enough light to get through the lens for a proper exposure. This is why a sturdy tripod and a shutter release are so important.

To get the depth of field needed for violin photography, often exposures of a second or longer are needed. The other important point is that depth of field is not linear, i.e., there is not an equal amount in front of, as behind the object focused upon. Instead, approximately one third of this distance is toward the camera from the focal plane and the remaining two thirds is behind the focal plane. In most circumstances this is not particularly important, but when photographing the scroll full frame, for example, it is critical to remember this. In this case one generally needs to focus on a point in the air, in between the pip or tip of the peg and the side of the scroll. In practice, this is counter-intuitive; to get the best focus, nothing is in focus through the viewfinder. If you use the preview lever you will see that as you close down the aperture, more and more of the picture comes into focus, until eventually the pip of the peg through to the far side of the peg box will be in sharp focus. It will likely take some experimenting to find the correct spot on which to focus for each individual lens, but this is the only technique we have found to have the entire side view of the scroll in focus.

Another point to remember is that as the camera gets close to the instrument, the maximum depth of field is dramatically reduced. For example, a full-frame shot of the middle bout, including the *f*-holes and the four corners, poses some difficulties with having enough focus depth. Any shot with extension tubes, even with the smallest aperture, will have very little depth of field, so it is important to take this into consideration when composing the picture.

### *Lighting*

Lighting is the bane of all photographers of varnished surfaces.<sup>2</sup> It is especially difficult for instruments of the violin family since the various arches cause unwanted reflections unless the lamps are strategically placed. In extreme cases, polarizing filters must be used, either on the lens or in front of the lights. The worst-case scenario is using a flash on the camera, which will give a huge reflection on the center of the arch. The general set-up of the lights should be positioned so that they are oblique to the surface being photographed. By carefully moving the individual lights, a generally reflection-free surface with sufficient light can be achieved. There are advocates of lights positioned only above the instrument, the thought being that this will provide greater contrast, but we have had trouble getting this technique to work. Another method is to have a complete array of lights, possibly twenty or thirty mounted permanently to a support, all facing the instrument at a very oblique angle. However, lighting is always very difficult for violins and the search continues for better techniques. Fortunately for us, the same lighting design has been used successfully for both studio work and fieldwork.

Whatever style one chooses, care must be taken to avoid heating the instrument. This can easily happen when using 2 kW of lighting. For studio work, each of the lights is connected to its own dimmer switch that leads to a board within reach of the photographer so that the lights can be turned on and off and their intensity adjusted from the camera (B&W only). This is ideal, as this is what the film sees. In the field, the lights are plugged into a computer strip, or the same dimmer array, that can be turned on and off whenever one is composing something that is not light reliant. We use a spot meter for studio work to insure that each quadrant of the violin is within a few tenths of a stop, but in the field this is perhaps a luxury. The bulbs are color-corrected photoflood lights to match whatever color intensity film is used.

### *Exposure*

With our particular equipment, the meter reading is correct for the full frame of the belly, back, and sides, but for the full instrument it is generally necessary to add one more stop. The same applies for a full-frame close-up photo of the belly. For close-up work with extension tubes, up to three additional stops may be necessary. (See the Appendix.) Large-format camera users are familiar with the bellows factor (extension tubes in the smaller formats), but most of us need not worry about this. The easiest way to find the correct exposure is to take a test roll of film, bracketing each type of photograph (full instrument, full body, close-up shots, etc.) with a stop or two to each side of the

metered reading. Take notes of the exposures, and when the film is developed, choose the exposure that worked for each type of picture. A listing is provided in our photographic worksheets for what we do with each type of photograph via the metering, and it is very simple after the initial testing to arrive at correctly exposed negatives.

With exposures longer than 1-2 seconds, one must address the issue of what is called *reciprocity failure*. This term refers to the decline of film sensitivity with exposure time. Generally, this is not an issue for color films (check the back of the film package for the “actual” speed at increased exposure), but it is a consideration when using B&W film. It’s really quite simple. One just refers to the graph that comes with the film to find that, for example, a nominal 2-sec. exposure will actually require five seconds. Each film is different and will have a slightly different graph for compensation. When developing film that has had a long exposure time, it is generally beneficial to increase the development time somewhat. Experiment in your own lab or have an outside lab do some testing for you. Doing your own B&W lab work can be very calming after a long, hectic day.

### Summary

With appropriate equipment plus some thought and care, anyone can produce high-quality photographs of musical instruments.

### ACKNOWLEDGMENTS

We would like to thank Jeff Loen and Brian Newnam for help with the editorial process that this article has undergone to make it understandable to the student photographer and Paul Trentelman for help from the perspective of a professional photographer.

### NOTES

1. In photographing musical instruments, one slightly longer than normal lens is usually adequate, but the term “interchangeable lenses” is used to distinguish between inexpensive cameras with fixed lenses and higher quality cameras that have the option of changing lenses.
2. In our experience natural light is useless for “study” shots as there is very little control of reflections. For “artistic” work this is not necessarily an issue.
3. This is one of the few times that we advocate digital work. In this case, an experienced Photoshop or similar type program user can adjust the color to match that of the instrument. This is not as easy as it sounds since the printer, monitor, and software must all be calibrated to the same specifications. The exchange is reduced print detail for



- study purposes.
4. This structure can be fabricated with welded aluminum in order to save weight.
  5. Always ask the owner if they will allow the chinrest to be removed for the photographs; never assume that this is "standard."
  6. Another option would be to use a very long telephoto lens to "bring the instrument closer," thereby filling more fully the frame and utilizing the film. However, this lens is expensive and would likely not produce as sharp a photograph as one with a more "normal" lens length.

#### REFERENCES

- [1] S. Pollens, Violin photography technique, *J. Violin Soc. Am.*, Vol. X, No. 2, pp. 199-210 (1990).
- [2] H.A. Strobel, Photographing violins, in *Violin Maker's Notebook*, 4th ed. (publ. by the author, Aumsville, OR, 1997), pp. 44-51.
- [3] R. Valencia, In the picture (Guide to string instrument photography), *The Strad*, Vol. 110, No. 1311, pp. 732-737 (July 1999).
- [4] J. Jackman, Choosing the right lighting kit, available on the internet (as of May 2005) at <[www.ifvchicago.com/process/prod\\_lighting\\_a01.shtml](http://www.ifvchicago.com/process/prod_lighting_a01.shtml)> (from digitalvideo.com).
- [5] R. Ward, Picture perfect, *Strings*, Vol. XX, No. 1, pp. 20-23 (June/July 2005).
- [6] A. Adams, *The Camera* (Ansel Adams repr. ed., 1995).
- [7] A. Adams, *The Negative* (Ansel Adams repr. ed., 1995).
- [8] A. Adams, *The Print* (Ansel Adams repr. ed., 1995).

#### APPENDIX

The following referral sheet serves as a photo checklist designed for use in the field. It is a reminder of certain settings that are easy to forget in a rushed shoot. It also has a section to keep track of camera settings to aid in processing the film.

Photo checklist				
<b>General guidelines</b>				
	Periodically check back rotation			
	Check heat levels			
	Check that shutter is set to work properly (Man/Auto)			
<b>Meter settings</b>				
	Full instrument back and belly		Meter + 1.5	
	Full instrument side view		Micor	
	C-bout central view		Meter + 1	
	With #1 tube		Meter + 2	
	With #1 and #2 tube		Meter + 2.5	
<b>Shots</b>		Meter	#1	#2
	Full instrument belly			
	Full belly			
	C-bout central view			
	Full instrument back			
	Full back			
	C-bout central view			
	Full instrument side			
	Full side			
	Bass ff with #1 tube			
	Treble ff with #1 tube			
	Misc shots with both tubes			
	Scroll side bass			
	Scroll front			
	Scroll back			
	Scroll side treble			
	Misc. shots with both tubes			